

Invention

WINTER 2018

THE MAGAZINE OF THOMAS EDISON STATE UNIVERSITY



University Selects New President

Merodie A. Hancock, Ph.D.

INSIDE:

45TH ANNUAL COMMENCEMENT

ALL IN: MATTHEW LEVINSON, MBA '17

PERSONALIZING MEDICINE:
ALLISON ADAMOUSKY, MSAST '16

BUILDING A BETTER FUTURE:
STEPHEN JONES, BSAST '12, MSHS '16

SERVICE TO COUNTRY AND COMMUNITY:
TYSHAWN JENKINS, MBA '15



3



5



8



12



14

1 > President's Message

UNIVERSITY NEWS

- 2 > Thomas Edison State University Approved for First Competency-Based Degree Program
- > University Launches New Undergraduate Certificate in First-Year Foundations
- 3 > Grant from New Jersey Council for the Humanities Allows for "Dialogues on the Experience of War" Project

FOUNDATION NEWS

- 4 > Scholarship Highlight: Xaymara Reynolds, MSHRM '17
- 5 > University Receives \$150K in Grants from Investors Foundations to Fund Expansion of Nursing Programs
- > Wells Fargo Awards \$10,000 Grant to Help Teachers Become More Culturally Competent Educators

COVER STORY

- 6 > University Selects New President
- 8 > Thomas Edison State University Celebrates 45th Annual Commencement

ALUMNI PROFILES

- 12 > All In: Matthew Levinson, MBA '17
- 14 > Personalizing Medicine: Allison Adamousky, MSAST '16
- 16 > Building a Better Future: Stephen Jones, BSAST '12, MSHS '16
- 18 > Service to Country and Community: Tyshawn Jenkins, MBA '15

20 > Class Notes

Invention is published quarterly and is produced by the Office of Communications and the Office of Institutional Marketing at Thomas Edison State University.

Dr. George A. Pruitt
PRESIDENT

Joe Guzzardo
EDITOR

Kristen Lacaillade
Kelly Saccomanno
Linda Soltis
CONTRIBUTING EDITORS

Chris Miller
ART DIRECTOR



DEAR ALUMNI, STUDENTS AND FRIENDS,

I am pleased to share with you that the University Board of Trustees has selected Dr. Merodie A. Hancock as the next president of Thomas Edison State University.

We are honored to introduce you to Dr. Hancock in this issue of *Invention*. She currently serves as president of SUNY Empire State College in New York. Dr. Hancock has dedicated her career to serving adults and has a particular passion for supporting military service members and veterans. I could not be more pleased that she will be our next president.

We are also excited to introduce you to alumni who have made a noteworthy difference in the lives of others through their work and volunteer pursuits.

Matthew Levinson, MBA '17, former chair and CEO of the New Jersey Casino Control Commission, Allison Adamousky, MSAST '16, an associate director pharmacovigilance scientist at Bristol-Myers Squibb in Hopewell, N.J., Stephen D. Jones, BSAST '12, MSHS '16, a recently retired construction official for the Township of Millburn/Short Hills and the Borough of Florham Park in New Jersey, and Tyshawn Jenkins, MBA '15, service member and entrepreneur, all share how completing their education has paid dividends in each of their lives.

Finally, we are thrilled to share stories and photos from our 45th Annual Commencement, which took place on Sept. 23 at the Sun National Bank Center (now CURE Insurance Arena) in Trenton. Our annual Commencement is the greatest day of the year for the institution, and this year was particularly special for me as it was my last as president of the University.

I hope you enjoy this issue of *Invention*.

Sincerely,

George A. Pruitt
President

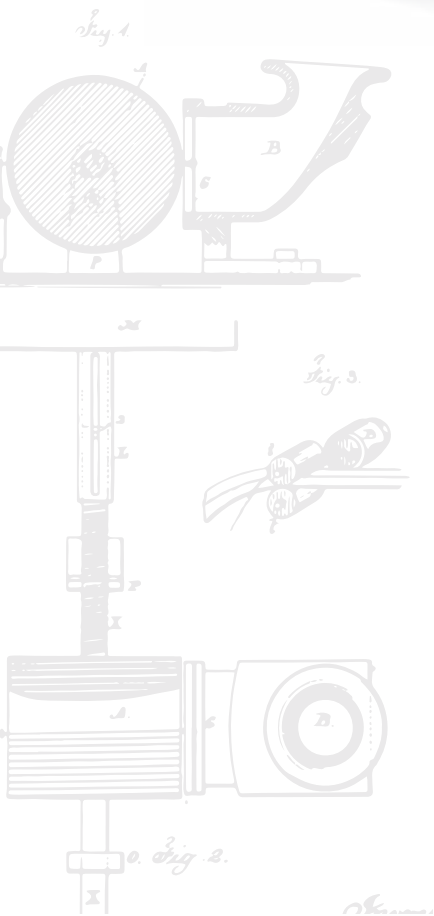

Thomas Edison State University Approved for First Competency-Based Degree Program

Thomas Edison State University has received approval from the Middle States Commission on Higher Education to offer the institution's first competency-based education degree program, an Associate in Arts degree.

The competency-based Associate in Arts degree, with an area of study in Liberal Studies, is scheduled to be available this summer. It will be the first competency-based degree program offered by a New Jersey college or university.

"Thomas Edison is only the second institution in the Middle States region to receive this type of approval, and we look forward to continuing our work as an innovator in higher education," said William Seaton, provost and vice president for Academic Affairs at the University.

Competency-based education enables students to leverage knowledge they

already possess to demonstrate mastery of competencies associated with a degree program or certificate, rather than spend time completing a course. The University's program will utilize an approach known as direct assessment, where students pass assessments that demonstrate they have mastered defined learning objectives to earn their degree.

"Our goal is to create a strong alignment between our competency-based programs and the needs of employers and working adults," said Marc Singer, vice provost of the University's Center for the Assessment of Learning. "We plan to focus on



Marc Singer, vice provost of the University's Center for the Assessment of Learning

competencies that are essential for particular fields of work, which should make them attractive to our corporate partners and our students."

Development of the University's first competency-based program has been supported by grants from the Thomas Edison State University Foundation.

University Launches New Undergraduate Certificate in First-Year Foundations

The University has developed a new undergraduate certificate in First-Year Foundations which can be completed entirely through the use of open educational resources.

"Students will be able to earn this credential by taking self-paced courses paired with rigorous assessments," said Dr. John Woznicki, dean of the Heavin School of Arts and Sciences at the University under which the certificate will be offered. "This certificate will provide students with the foundation they need in general education and the liberal arts to complete their degrees and will serve as a complement to their chosen degree program."

The certificate will fulfill some of the General Education requirements toward a bachelor's or associates degree program at Thomas Edison State University. It is comprised of 10 courses, allowing students the ability to earn 30 credits toward their chosen degree.

"Smaller, stackable credentials such as this certificate give validation to students for all they have accomplished," said Marc Singer, vice provost, Center for the Assessment



Dr. John Woznicki, dean of the Heavin School of Arts and Sciences

of Learning at the University. "It is aimed to demonstrate that students are making progress toward degree completion and is awarded to emphasize their commitment to education."

For more information about the University's undergraduate certificate in First-Year Foundations, visit www.tesu.edu/foundationcert.

Grant from New Jersey Council for the Humanities Allows for “Dialogues on the Experience of War” Project

Thomas Edison State University’s Heavin School of Arts and Sciences and the Office of Military and Veteran Education presented the second of two discussion-based workshops entitled, “Dialogues on the Experience of War,” on Oct. 30 and 31 at The National Guard Armory/Joint Military and Family Assistance Center in Bordentown, N.J. Funding for the workshops came through a nearly \$20,000 grant from the New Jersey Council for the Humanities (NJCH) awarded in early 2017.

The workshops consisted of multiple sessions on different war-related topics and underscored the role of humanities

“I can always go back to my time in the military and years as a Marine and realize what it took for me to go through boot camps, my duty stations in Japan and South Korea and my day-to-day service jobs far away from home,” said University alum and U.S. Marine Corps veteran Daniel Sanabria-Morales, BA ’13, who participated in the workshops. “When I came back to the civilian side, there was no compass, no unit camaraderie, no chain of command. I gathered the strength and discipline I learned in the Marine Corps and take it with me wherever I go. Having the ability to talk about my experience in

Sciences, who oversaw the project at the University. “One of the goals of the project was to help past and present military veterans understand the wider experience of war beyond their own sense of it, one as articulated by humanities scholars and war veterans throughout the years.”

The first set of workshops was held on June 5 and 6 at the New Jersey Veterans Memorial Home in Menlo Park, N.J.

“We were so happy to support this project and Thomas Edison State University in doing this important work,” said Dr. Briann Greenfield,



Pictured, from left, Daniel Sanabria-Morales, BA ’13 and Marine Corps veteran discusses his experience at the event; U.S. Air Force veteran and current TESU student Leonardus Kittles at the Dialogues event in Bordentown, N.J.; Gary Hasenbalg, U.S. Army Veteran and N.J. Department of Labor and Workforce Development Chief of Staff (left in glasses) with David Longenbach, presenter and TESU History mentor; and U.S. Army veteran and N.J. National Guard service member, Joe Nyzio.

in helping civilians understand the experiences of U.S. service members while encouraging military and veteran participants to share their insights.

Discussion leaders, including historian and TESU mentor David Longenbach and Craig Smith, director of Veteran Affairs at the University, presented material from books, articles, theater and films offering a variety of perspectives on the experience of war and the reintegration of the veteran into civilian society. Participants in the October workshops were also treated to a live performance by author/actor Douglas Taurel of scenes from his one-man show, *The American Soldier*.

This program was made possible by a grant from the New Jersey Council for the Humanities, a state partner of the National Endowment for the Humanities. Any views, findings, conclusions or recommendations expressed in this publication do not necessarily represent those of the National Endowment for the Humanities or the New Jersey Council for the Humanities.

this workshop was very helpful in this process.”

Historically, military personnel have faced challenges when reintegrating into civilian society. Engaging with those who have experienced similar obstacles and those providing support services is vital in overcoming these challenges.

“The Heavin School of Arts and Sciences provides an interdisciplinary approach to lifelong learning for adult learners interested in exploring the liberal arts and sciences, including the humanities,” said Dr. John Woznicki, dean of the Heavin School of Arts and

executive director for the New Jersey Council for the Humanities. “For us, the study of the humanities and the cross-generational experiences shared in these sessions have such power in helping us shape and share our values and beliefs and build together a stronger, pluralistic society. The “Dialogues” sessions helped us to understand more broadly what it means to be ‘of service’ to your country and prompted those who have served to think about and share their own experiences.”



NEW JERSEY COUNCIL
FOR THE HUMANITIES

❖ Scholarship Highlight: **Xaymara Reynolds, MSHRM '17**

For many, scholarship support can be the difference between completing a degree and taking a hiatus. Xaymara Reynolds knows about this kind of support.

A 2017 graduate of Thomas Edison State University's Master of Science in Human Resources Management degree program, Reynolds characterized her experience at the institution as "beyond the standards of higher education."

"Thomas Edison was convenient for me," she said. "The advantage of online learning allowed me to spend time with my family as well as maintain a full-time job. I don't think I would have finished my degree any other way."

Reynolds, who works as an administrative analyst for the state of New Jersey, received not only moral support from her family and friends throughout her degree completion, but also financial support from the American Federation of Teachers (AFT) Local 4277 by way of a scholarship the organization established in 2013.

The scholarship, funded by matching grants from the AFT Local 4277 of Thomas Edison State University and

its senior organization, the Council of New Jersey State College Locals, AFT/AFL-CIO, is awarded to New Jersey residents who are active union members and currently enrolled in or seeking enrollment in a graduate program at the

University. AFT Local 4277 is comprised of professional staff employees at the institution.

"The scholarship helped me complete my studies, period," she explained.

"Thanks to this financial support, I was able to both fund my courses as well as maintain my personal finances at home.

I am so grateful for this support in aiding me to complete my studies."

On her experience throughout her degree completion, Reynolds echoed the same sentiment of thankfulness.

"My professors, Dr. Kenneth Levitt and James Krolik made a positive impact on my learning," Reynolds said. "Words cannot describe the support that these professors give their students. With their guidance and knowledge, I was

"THANKS TO THIS FINANCIAL SUPPORT, I WAS ABLE TO BOTH FUND MY COURSES AS WELL AS MAINTAIN MY PERSONAL FINANCES AT HOME. I AM SO GRATEFUL FOR THIS SUPPORT IN AIDING ME TO COMPLETE MY STUDIES."

Xaymara Reynolds

able to better understand the world of human resources. My experience with the University overall was amazing."

Reynolds lives in New Jersey with her husband Jerome, and the couple's 11-year-old son.



University Receives \$150K in Grants from Investors Foundations to Fund Expansion of Nursing Programs

Thomas Edison State University has recently received \$150,000 in grants from the Investors Foundation and the Roma Bank Community Foundation to fund the further expansion of the University's graduate-level nursing programs.

"We are grateful to the Investors and Roma Bank Community Foundations for their continued support of our nursing programs," said Dr. Filomela Marshall, dean of the W. Cary Edwards School of Nursing at the University. "These funds will make it possible for us to continue to provide a superior nursing education to our current students and those looking to complete their degrees, in turn, immersing even more qualified, competent nursing professionals into the field."

These funds, from both the Investors Foundation and the Roma Bank Community Foundation, will be dispersed as two five-year installments

of \$15,000 each. Roma Bank became part of Investors Bank in December 2013.

These grants will support key initiatives such as the development of additional graduate-level nursing programs; important equipment needed for the implementation of a birthing room in the School's nursing simulation laboratory; and essential annual maintenance, ensuring the ongoing functional capabilities of the equipment, technology, software and human patient simulators in the laboratory.

"The Investors Foundation and Roma Bank Community Foundations are privileged to be able to offer continued support to the W. Cary Edwards School of Nursing," said Investors Bank Senior Market Manager, Linda Martin. "The kinds of innovative and flexible programs offered by the School ensure an ability to meet the healthcare needs of our communities. Students will learn



Pictured, from left to right, are Linda Martin, senior market manager, Investors Bank; Dr. Filomela Marshall, dean of the W. Cary Edwards School of Nursing at Thomas Edison State University; Fred Brand, director of Corporate and Foundation Relations at Thomas Edison State University; Peggi B. Shader-Gotter, assistant vice president, branch manager, Investors Bank; and John P. Thurber, vice president for Public Affairs at Thomas Edison State University.

to master complex skills for a clinically competent and technologically adept workforce."

Wells Fargo Awards \$10,000 Grant to Help Teachers Become More Culturally Competent Educators

Wells Fargo has awarded a \$10,000 grant to Thomas Edison State University as part of its commitment to giving back to the community. The grant provides support to a mentoring program based in The John S. Watson Institute for Public Policy of Thomas Edison State University that helps early childhood and elementary school educators become more culturally aware of students from diverse backgrounds.

The New Jersey Cultural Competency and English Language Learners (ELL) Summer Institute and Mentoring Program, launched in 2007, is coordinated by the Watson Institute's Center for the Positive Development of Urban Children.

"The funding continues to support the centerpiece of the ELL Program – mentoring and monitoring of teachers who work with the state's diverse population of children – by giving them

the tools to become more culturally and linguistically responsive educators," said Ana I. Berdecia, MEd, center director. We are immensely grateful to Wells Fargo for its support of this endeavor."

Since its launch, ELL has trained and mentored 235 educators working in 97 classrooms across 85 schools throughout New Jersey. This year's program focuses on working with preschool to third grade classrooms in both Trenton and Carteret Public Schools.

"New Jersey is increasingly a diverse state with children and their parents coming from other countries speaking many languages," said Deborah Smith, head of the Wells Fargo Foundation for New Jersey, New York and Connecticut.

"Thomas Edison's program is critical because it assists educators in teaching thousands of children English as a second language and it helps them to recognize cultural differences.



Pictured front row, from the left, are Chemisa Coombs, branch manager, Wells Fargo; Brittany Russo, district manager for Mercer County South, Wells Fargo; Chad Acosta, district manager for Greater Princeton, Wells Fargo; and Ana I. Berdecia, director, Center for the Positive Development of Urban Children, Thomas Edison State University. Back row, from the left, are Frederick S. Brand, director of Corporate and Foundation Relations at the University; Barbara George Johnson, executive director, The John S. Watson Institute for Public Policy at the University; and Tom Kim, branch manager, Wells Fargo.

Wells Fargo is pleased to support this initiative through our Foundation as well as others which support teachers and students."



University Selects New President

Merodie A. Hancock, Ph.D., Scheduled to Take Office on March 5

Merodie A. Hancock, Ph.D., was unanimously elected the fourth president of Thomas Edison State University by the institution's Board of Trustees at a special board meeting on Dec. 20. She will take office on March 5.

"Thomas Edison State University is such a respected pillar among adult-serving institutions in the United States and has been at the forefront of offering degree pathways for busy, working adults since its inception in 1972," said Hancock, who currently serves as president of SUNY Empire State College in New York. "I hold dear this mission, and am honored to take on the presidency of such a pivotal University."

"DR. HANCOCK HAS DEDICATED HER DISTINGUISHED CAREER TO EXPANDING ACCESS TO HIGHER EDUCATION FOR ADULTS, INCLUDING ACTIVE MILITARY SERVICE MEMBERS AND VETERANS, AND IS A NATIONAL LEADER IN MEETING THE UNIQUE NEEDS OF NONTRADITIONAL STUDENTS."

Brian T. Maloney

University Board Chair Brian T. Maloney said Hancock's record of accomplishment and commitment to innovation and excellence made her an ideal choice to lead Thomas Edison State University.

"We are honored and excited to have Dr. Hancock as our new president. She has the experience, expertise and vision to lead Thomas Edison in today's challenging marketplace," said Maloney, who chaired the University's



Merodie A. Hancock, Ph.D., was selected to serve as the fourth president of Thomas Edison State University and will take office on March 5.

presidential search committee. “Dr. Hancock has dedicated her distinguished career to expanding access to higher education for adults, including active military service members and veterans, and is a national leader in meeting the unique needs of nontraditional students.”

Hancock has served as president of SUNY Empire State College since 2013. She is responsible for the overall operation of the institution’s 35 locations throughout New York,

“I LOOK FORWARD TO JOINING THE THOMAS EDISON TEAM AS WE BUILD ON A GREAT FOUNDATION, CONTINUING TO SERVE THE ADULT STUDENT WITH INNOVATION AND EXCELLENCE.”

Merodie A. Hancock, Ph.D.

the worldwide Center for Distance Learning and eight international sites and oversees the teaching and learning of the college’s 20,000 students, as well as the employment of 1,700 faculty and staff and active engagement with 70,000 alumni.

Prior to joining SUNY Empire State College, Hancock served as vice president at Central Michigan University Global Campus where she was responsible for delivering academic programs at the university’s remote campuses, military and community college locations and online programs. During her tenure at Central Michigan, Hancock served on several strategic committees and oversaw tuition pricing and discounting strategies, compliance with accreditation and licensure regulations, partnerships with community colleges and increased diversity recruitment. She has also held teaching and administrative leadership positions at the University of Maryland University College and Embry-Riddle Aeronautical University.

Dr. George A. Pruitt, who will officially leave office after serving as Thomas Edison’s president for 35 years, praised the board’s selection for the institution’s new president.

“I am delighted that Merodie Hancock will be the next president of our

University,” said Pruitt. “She is a tested executive, an experienced educator and a visionary leader who has spent her career in our academic space and understands how technology can remove barriers in higher education to meet the needs of adults. Her passion for serving members of our military and veterans will also serve the Thomas Edison State University community well.”

The University’s presidential search began shortly after Pruitt announced his plans to step down from the office in June 2017.

The University formed a presidential search committee and conducted an extensive national search that attracted many qualified candidates. Chaired by Maloney and assisted by the executive search firm Heidrick and Struggles, the committee included university trustees Frank Clyburn, president, Global Oncology, Merck & Co., Inc.; Eric Lear, managing partner, Lear and Pannepacker, LLP; and Gualberto (Gil) Medina, executive vice president, CBRE, Inc.; as well as Amy Mansue, president, Southern Region, RWJBarnabas Health; Judy Persichilli, former president and CEO of Catholic Health East; and Denise Rogers, vice chancellor for Interprofessional Programs at Rutgers Biomedical and Health Sciences.

“[DR. HANCOCK] IS A TESTED EXECUTIVE, AN EXPERIENCED EDUCATOR AND A VISIONARY LEADER WHO HAS SPENT HER CAREER IN OUR ACADEMIC SPACE AND UNDERSTANDS HOW TECHNOLOGY CAN REMOVE BARRIERS IN HIGHER EDUCATION TO MEET THE NEEDS OF ADULTS. HER PASSION FOR SERVING MEMBERS OF OUR MILITARY AND VETERANS WILL ALSO SERVE THE THOMAS EDISON STATE UNIVERSITY COMMUNITY WELL.”

Dr. George A. Pruitt

“On behalf of the board, I would like to extend my sincere thanks to our committee members who did a tremendous job conducting this search,” said Maloney. “This work has culminated with an extraordinary new leader for Thomas Edison State University.”

Hancock has been involved in several professional organizations, including the Distance Education Commission Advisory Group, Inside Track Advisory Board, Council of College and Military

Educators, League for Innovation, National Association of Institutions for Military Education Services (past president) and the National Commission on Online Learning Benchmarking Study. She has also served as an external reviewer for several universities and participated in numerous self-studies, reports and evaluation visits for regional accreditors, the Department of Defense, state approving agencies and specialized accrediting organizations, and has made presentations at professional conferences and meetings on topics such as strategic partnerships, pricing models and innovative teaching best practices.

Hancock holds a Ph.D. in urban services and education administration from Old Dominion University, an MBA from Claremont Graduate University and a Bachelor of Arts in Economics from Scripps College. Additionally, she has a certificate from the Institute of Educational Management from Harvard University, a certificate from the University Professional Continuing Education Association Leadership Academy at New York University, a certificate in Process Design and Implementation: Reengineering and Change Management from Michael Hammer and Company and a certificate in Nonprofit Board Leadership from

the Dorothy A. Johnson Center for Philanthropy.

“I offer my thanks to President Pruitt for his years of service and leadership of TESU and to the Board of Trustees, whose passion for the University and its mission is so apparent,” said Hancock. “I look forward to joining the Thomas Edison team as we build on a great foundation, continuing to serve the adult student with innovation and excellence.”

2017 Commencement

Thomas Edison State University Celebrates 45th Annual Commencement

Thomas Edison State University celebrated its 45th annual Commencement, on Saturday, Sept. 23, 2017 at the Sun National Bank Center (now CURE Insurance Arena), where more than 440 graduates from 27 states as well as Guam, Malaysia and Italy traveled to Trenton, N.J., to participate in the ceremony.



Eric Capponi, ASBA '15, BSBA '16, of Ocean Township, N.J., gave the response for graduates

Eric Capponi, ASBA '15, BSBA '16, of Ocean Township, N.J., gave the response for graduates. He has worked professionally in the global IT services industry for more than 30 years and has completed assignments in North America, Europe, Asia and Australia, currently working as a principle solutions architect for a technology start up located outside Boston, Mass. When giving his response, Capponi reflected on success as it relates to pathways to degree completion.

"It's important for us to remember that success is not a destination, but a journey," he said. "A grand adventure we embark upon to improve ourselves, our lives and the lives of those close to us. As adult learners, we perceive the challenge and set goals for ourselves. And today, we've reached these goals and attained success. Success is not an easy task. If it was, it would be worth less in pursuing."

Capponi left graduates with a quote from a former president about the result of hard work and perseverance.





“To quote John F. Kennedy, ‘We do these things not because they are easy, but because they are hard.’ Success is a result of effort, and it is this effort that makes this a worthwhile journey,” Capponi said.

The University also awarded an honorary degree to Richard W. Arndt, who has served with distinction on the Thomas Edison State University Board of Trustees since 1993. Arndt was executive vice president and CEO of the American Cancer Society’s (ACS) New Jersey Division from 1990 through 2000. Prior to that, he held executive-level positions within the ACS’ New Jersey Division, including executive vice president, deputy executive vice





Richard W. Arndt, honorary degree recipient, addresses graduates and guests at 45th annual Commencement.



president, and director of Field Services. Arndt retired from the ACS after 37 years of service. Prior to his distinguished career, he served for three years in the United States Army Security Agency and was stationed in the Philippine Islands for 18 months. He is the recipient of a Good Conduct Medal, received a Field Station Commendation and is the recipient of numerous awards, honors and commendations as a result of his philanthropic work.

“I am truly honored and most appreciative to receive an honorary doctor of humane letters degree,” he began. “I have thoroughly enjoyed being a part of this great institution as it has expanded its academic programs while continuing the emphasis on high-quality education for adult learners. I have attended many commencements over the years, and I am always inspired by the graduates’ abilities to juggle the demands of their family life, jobs and education. I want





Dr. George A. Pruitt receives a standing ovation after being recognized for his 35 years of service to the institution.

to thank Dr. Pruitt for the friendship and courtesies he has extended me during my 24 years as a volunteer.”

The Class of 2017 included more than 2,586 graduates. The University has awarded approximately 59,225 degrees to more than 52,000 graduates since it began providing flexible, high-quality, collegiate learning opportunities for self-directed adults in 1972.

To watch the 45th annual Commencement ceremony, visit www.tesu.edu/commencement.



ALL IN

Matthew Levinson, MBA '17

Matthew Levinson performed a unique balancing act as part of his role at the New Jersey Casino Control Commission.

Levinson, who served as chair and chief executive officer of the Commission from 2012 to 2017, saw Atlantic City, N.J., and its regulatory environment through unprecedented change. He streamlined the size and the scope of the Commission in response to significant changes in the gaming industry, competition, the economy and the state's gaming law. Levinson realigned the staff, rightsized the number of employees and reduced expenses, transforming it into an effective, efficient government agency, all while maintaining an impartial position.

"I was appointed at a time when the casino industry was in crisis, and I would like to think I played some role in helping the industry to right itself and turn around so that we could reap the economic benefits of gaming," he said.

This righting of the ship, for Levinson, came from humble beginnings growing up in southern New Jersey.

The son of an educator, Levinson recalled how his parents consistently stressed the importance of obtaining an education. "My parents instilled in me the value of a good education and how important it is in order to get ahead in life," he said. "My father was an educator and his example had a big impact on me. I want to pass that along to my two young sons and show them that they should always strive to learn more and that by learning more they can go further."

To underscore the example he was looking to set, Levinson went on to earn his undergraduate degree in

accounting with a minor in finance from Villanova University in Villanova, Pa., later earning a Master of Business Administration (MBA) degree from Thomas Edison State University in 2017.

"With my undergraduate degree in accounting, an MBA was a natural move to advance my education, learn more and improve my skills," he explained. "The courses throughout the program exposed me to different ways of looking at and solving problems that I could, and did, use in real-life situations at work, while also helping me to hone my leadership skills."

In addition to improving his skills, Levinson credits the University's program flexibility for allowing him to make advancing his education possible.

"The University gave me the opportunity to pursue a degree from an accredited university with online courses that fit into my busy schedule," he explained. "While graduate-level work is demanding, it was worth it for me. I can see it paying dividends already, and I am sure that this degree will have a major impact on my future."

Early on in his professional career, Levinson worked for the international forensic accounting firm of Matson,

Driscoll & Damico, LLP, where he performed forensic accounting work relating to the 2001 attack on the World Trade Center and the 2003 collapse of a parking garage under construction at the Tropicana Casino and Hotel in Atlantic City. He later went on to work his way through the casino and gaming industry beginning as a casino accounting manager at Resorts International Hotel Casino, later moving into a role as a senior operations analyst with responsibilities in both the gaming and non-gaming areas of the property.

Immediately prior to his appointment to the Commission, Levinson served as the chief financial officer of SOSH Architects for the firm's offices in Atlantic City and in New York City.

"THE UNIVERSITY GAVE ME THE OPPORTUNITY TO PURSUE A DEGREE FROM AN ACCREDITED UNIVERSITY WITH ONLINE COURSES THAT FIT INTO MY BUSY SCHEDULE. WHILE GRADUATE-LEVEL WORK IS DEMANDING, IT WAS WORTH IT FOR ME. I CAN SEE IT PAYING DIVIDENDS ALREADY, AND I AM SURE THAT THIS DEGREE WILL HAVE A MAJOR IMPACT ON MY FUTURE."

Matthew Levinson

On a day-to-day basis, Levinson oversaw the state agency with a budget in excess of \$7 million and led the Commission that is chiefly responsible for licensing casinos in Atlantic City and their key employees.

"It was our job to insure that people in the gaming industry met the state's standards for good character, honesty and integrity while maintaining public confidence in the industry and the regulatory process," he explained. "In my role, I oversaw a staff of nearly 40 people who conducted in-depth research into the impact of gaming in Atlantic City, performed financial stability analyses on casino license applicants



alumni profile

and audited the fees generated by casino hotels.”

In addition to his role as chair, Levinson was also a member of the Casino Reinvestment Development Authority (CRDA), which directs the reinvestment of casino revenues into projects to help rebuild and revitalize Atlantic City.

“THE COURSES THROUGHOUT THE (MBA) PROGRAM EXPOSED ME TO DIFFERENT WAYS OF LOOKING AT AND SOLVING PROBLEMS THAT I COULD, AND DID, USE IN REAL-LIFE SITUATIONS AT WORK, WHILE ALSO HELPING ME TO HONE MY LEADERSHIP SKILLS.”

Matthew Levinson

Looking at his position from a birds-eye-view, Levinson reflected on the part he played on a larger scale and how his work will affect the future of the city for years to come.

“What inspires me most about what I was tasked to do is the ability I had to make an impact on the future of Atlantic City and on the lives of thousands of people who depend on the gaming industry,” he said. “I am also inspired by how I contributed to reshaping the face of Atlantic City. Through my position on the board of the CRDA, I had also been involved in approving projects that help to make Atlantic City a better place to live, work and visit.”

Levinson currently serves on the Board of Directors of the Levinson Institute of Gaming, Hospitality and Tourism at Stockton University and the board of Main Street Atlantic City, a nonprofit organization that manages and guides the revitalization of Atlantic City’s central business district. He has also been active in a variety of civic, professional and charitable organizations. Levinson is currently exploring outside business pursuits since his term with the Commission ended in 2017.

He was born and raised in Atlantic County, N.J., where he has lived and worked most of his life. Levinson currently resides in Linwood, N.J. with his wife and two children.



PERSONALIZING MEDICINE

❖ Allison Adamousky, MSAST '16

Allison Adamousky knows that in her career, nothing is guaranteed. But a master's degree helps remove much of the doubt.

"I always relied on my work experience for job security and, at one point, had to re-interview for my own position because I didn't hold a graduate degree," Adamousky began. "In order to remain relevant in this expanding marketplace, it was crucial that I keep pace with millennials who were coming into similar positions already possessing a master's or, in some cases, doctoral degree."

With the encouragement of her sister, Amanda, who had recently completed the same program at the University, Adamousky enrolled in the Master of Science in Applied Science and Technology (MSAST) degree program in Clinical Trials Management in order to supplement her 20 years of experience and to keep pace with the educational demands of her field, graduating in 2016.

For the past 20 years, she has been employed with Bristol-Myers Squibb at its Hopewell, N.J., location where she works as an associate director pharmacovigilance scientist, a position Adamousky was promoted to shortly after earning her master's degree.

She is tasked with analyzing data for prescription drugs that are still in their initial testing phase as well as for their large volume marketed products. Throughout these trials, she tracks the drugs' side effects in tandem with teams of doctors, scientists and pharmacists in order to begin to develop their warning labels. Of the four phases these

pharmaceuticals go through, each is intended to answer a specific question in the further evolution of the drug.

Adamousky, who earned her undergraduate degree in business communications from Rosemont College in Bryn Mawr, Pa., in 2000, explained that at any given time she

Adamousky said that complementing her work experience with her studies has allowed her to strike the right balance in her position each day.

"All of the pharmaceuticals that I am responsible for and that are in production live in a database from which I generate meticulous reports and data analysis that is provided to numerous agencies, including the Food and Drug Administration," she said. "These trial phases allow us time to build the most accurate drug label

"IN ORDER TO REMAIN RELEVANT IN THIS EXPANDING MARKETPLACE, IT WAS CRUCIAL THAT I KEEP PACE WITH MILLENNIALS WHO WERE COMING INTO SIMILAR POSITIONS ALREADY POSSESSING A MASTER'S OR, IN SOME CASES, DOCTORAL DEGREE."

Allison Adamousky

is assigned to three or four drugs for which she is solely responsible, from the moment they begin their trials through the life of the products.

"My job involves a lot of medical writing for which much of my undergraduate knowledge comes into play, however, my graduate work has been a crucial asset in allowing me to better understand the inner workings of the pharmaceutical and risk management industries," she said. "We begin our trials or treatments in a small group to start, which then builds to a larger group in the second phase. By phase three, the drug is further monitored to gather as much information as possible to determine side effects and proper dosing before finally being marketed."

possible, which includes the warnings that appear before the drug is put out for sale and can be prescribed by doctors for patients to begin use outside of their trials."

She admits, however, that throughout these trials, her family is often on her mind. "I think about their safety and ask myself, 'is this a drug I would give them?'" Our patients remain number one in my mind," Adamousky said.

Adamousky had long desired to continue her education and found the opportunity once her children became more independent.

"The time was right for me since my girls were older, and I was able to focus on myself," she explained. "Seeing what a positive experience my sister had



alumni profile

completing the program as a working adult gave me the push I needed to enroll.”

Adamousky went on to spend her nights and weekends for the next three years, one course at a time, tackling her assignments and interacting with peers through course discussion boards.

“The flexibility of the program was what drew me in,” she said. “Between commuting, feeding kids, putting them to bed, doing homework and balancing it all, the program really appealed to me. One of the best parts of the program, aside from the course content, was the interaction I had with my peers, particularly those who were stationed overseas in the military. I often responded to every one of their posts, though it wasn’t required, and feel that I got so much more out of the course through these exchanges as a result.”

When Adamousky is not wrapped up in tracking clinical trials, she spends her downtime tending to one of her longtime passions: animal rescue. Since 2012, she has been a volunteer and adoption event coordinator with the nonprofit, feral cat rescue, Forgotten Cats, which has a handful of locations across Pennsylvania and Delaware.

Adamousky, who has three cats of her own, fosters anywhere from three to four of the organization’s cats at one time, in a designated room in her home. All of the cats, who are classified as seniors, disabled or both, are able to live out their last days in comfort and not in an animal shelter.

“It’s something I’ve always had a heart for and to know that these cats live their final days in a safe environment is all I can ask for in providing them care,” she said. She also looks after two colonies of feral cats providing them with basic care and shelter to enable them to live their lives outdoors.

Adamousky lives in Pennsylvania with her husband and two daughters, Stephanie, 12, and Andrea, 17.



BUILDING A BETTER FUTURE

Stephen D. Jones, BSAST '12, MSHS '16

Since he was old enough to pick up a hammer, Stephen D. Jones has been involved in construction. In fact, it was while he was working as a construction manager in New York City that an educator helped guide him to a career choice that would change his life.

"I took my first code enforcement class back in 1988 with a gentleman named William Howard," Jones explained. "One evening he pulled me aside after class and asked what I was doing with my life. When I told him I was a construction manager, he shook his head and advised me to make a career out of code enforcement instead. He was right; it was the best decision I ever made, and I've never looked back."

Jones, a Certified Building Official (CBO) with more than 30 years of industry experience, recently retired from his dream job as the construction official for the Township of Millburn/Short Hills and the Borough of Florham Park in New Jersey. At Millburn and Florham Park, Jones was responsible for the daily operations of the departments. In addition, he participated in strategic and long-term planning as well as supervision of the zoning and code enforcement departments and managing numerous capital improvement projects.

"For me, being a code official was truly the best job ever," Jones enthused. He noted that the profession is important because it is imperative to develop model codes and standards that are used in the design, construction and compliance process to ensure safe, sustainable, affordable and resilient structures. He added that in light of all the recent natural disasters that struck Florida, Texas, California and Puerto Rico, the value of resilient buildings and infrastructure is a testament to effective

code development and enforcement, and why it is so important to build to the most current versions of the relevant codes.

A true leader in his field, Jones retains an impressive resume.

"IN THE EVENT THAT THERE IS A DISASTER IN NEW JERSEY, MUNICIPAL BUILDING INSPECTORS ARE RESPONSIBLE FOR PRIVATE DAMAGE ASSESSMENT, SO MY DEGREE IN HOMELAND SECURITY SEAMLESSLY FITS INTO EXACTLY WHAT I WAS DOING EVERY DAY OF MY PROFESSIONAL CAREER. MY HOMELAND SECURITY GRADUATE DEGREE PROVED A GREAT CHOICE FOR MY CAREER."

Stephen Jones

In addition to his national professional designation as a CBO, he is a Building Code Official who holds numerous state licenses and served on multiple state and national committees and boards, including the New Jersey Department of Community Affairs Peer Review Board and the Building Subcode Committee. Jones also serves on the National Institute of Building Sciences Council of Governments on Building Codes and Standards as well as holding the title of past president of the International Code Council (2013-2014), the Morris County Building Officials Association and the New Jersey Building Officials Association. He currently serves on the Morris

County Planning Board and the International Accreditation Services Board of Directors, and as a governor for the World Organization of Building Officials.

Based on his own experience, Jones is a firm believer in continuing education.

"Admittedly, finishing my degree was a long time coming," said Jones, who earned a Bachelor of Science in Applied Science and Technology (BSAST) degree in 2012 and a Master of Science in Homeland Security (MSHS) degree in 2016. "I had bounced back and forth between a number of schools over the years and I finally decided - I made a promise - that I would graduate before my oldest son did and, actually, he and I both graduated the same year. I graduated in January; he graduated in May."

Jones is such a proponent of the TESU programs that he was asked to serve on the Curriculum Committee of the John S. Watson School of Public Service and Continuing Studies and has been inducted into the National Honor Society for Homeland Security, Intelligence and Emergency Management, "Omicron, Sigma, Sigma," known as "The Order of the Sword and the Shield."

In addition to his duties as a municipal official, Jones served as the deputy OEM (Office of Emergency Management) director for those communities. "In the event that there is a disaster in New Jersey, municipal building inspectors are responsible for private damage assessment, so my degree in homeland security seamlessly fits into exactly what I was doing every day of my professional career. My homeland security graduate degree proved a great choice for my career."

Jones recently earned his professional designation as a New Jersey Certified



Emergency Manager (NJCEM), an accomplishment that was made easier with his background in homeland security obtained at TESU.

Jones expounded on how what one does daily in their field can translate into educational accomplishment.

“I have been involved in emergency operations and management in one form or another my entire adult life. I used to ride with an ambulance squad as an EMT for 11 years, so this also helped to solidify my background. One benefit of Thomas Edison’s generous credit acceptance programs for both my bachelor’s and master’s degrees was that all of the experience I gained from work, EMT classes, my state licensing classes, were all eligible to be rolled into my degree programs. When all of my credentials transferred, the journey to success was seamless. Once I finished my undergraduate degree, I took advantage of TESU’s bridge program. In what I considered my senior year, I was able to take my last 12 credits and rolled them into my master’s degree. It is one of the best opportunities at TESU; you get master’s credits at bachelor rates!”

While Jones notes earning his degrees at Thomas Edison was both challenging and rewarding, he shared his strategy with current and future students.

“What I found is that you have to be incredibly disciplined to succeed; you have to put time away every day,” Jones explained. “It’s very easy to get too far behind. If you stay focused and give yourself at least an hour or so a day, you can do it. While it may not happen overnight, you have to look at the end goal and know that eventually you will get there.” As a perpetual student, Jones noted that it may seem like it takes forever to complete the program, however, the feeling of accomplishment upon completion far exceeds the long nights of academic work.

Jones, who lives in East Hanover, N.J., enjoys spending time with his wife of 29 years, Paula, and their three adult children, Brian, Colleen and David. And, in keeping with his appreciation for continuing education, Jones is a community college instructor in the New Jersey Contractor EPA/HUD Model Renovator Training Program and working toward being a mentor for TESU.

Service to Country *and Community*

❖ Tyshawn Jenkins, MBA '15 ALUMNI AMBASSADOR

When all eyes are on you during a NBA game at Madison Square Garden, it is usually for a good reason or a great cause.

Tyshawn Jenkins, MBA '15, whose life is paved with good causes, was presented with a "Hoops for Troops" award during the New York Knicks vs. Boston Celtics game on April 2, 2017 by Knicks legend, Larry Johnson, at Madison Square Garden for service to his country and community.

The decorated U.S. Air Force staff sergeant and entrepreneur was selected for the award by "Hoops for Troops" partners the New York Knicks and Budweiser® for his efforts in creating a scholarship program for Asbury Park, N.J., High School students, serving as a mentor for Willingboro, N.J., middle school students and for his work as an ambassador for the Wounded Warrior Project and The Mission Continues programs.

Jenkins was also honored by the Brooklyn Nets in October as part of the team's "Brooklyn Nets Heroes Program" which recognizes returning armed forces veterans and first responders who have worked to protect the freedom and lives of all New York City-area people.

He managed these accomplishments while overseeing a photography and design firm, completing his Master of Business Administration (MBA) degree at the University and, even occasionally, carving out time to don a Spiderman costume at children's benefits.

He noted that, where an academic path such as his can be daunting, it is ultimately doable.

"Earning my MBA has helped me both as an entrepreneur and a service member. I have been able to use the knowledge I've gained in managing projects in my career and in leading fellow military personnel. As the executive director of Retouch Factory, I have utilized many of the tools that I learned while taking marketing courses including best practices and market research. These tools have been critical in helping me to create a brand that is growing every day."

Most would agree that the social responsibility components of Jenkins' course work also had a lasting effect. Seven percent of Retouch Factory's client billings go to a charity of his clients' choice. "I'm glad to have this built in to my business model and be able to give back to the community in this way," he noted.

"Tyshawn took advantage of our MBA preparatory coursework and the program's accelerated pace," said Camilla K. Lewis, assistant dean of Graduate Studies in the School of Business and Management. "He epitomizes military professionals honing their marketability through academic preparation and successfully transitioning to civilian life."

Jenkins extols the transformational effect his MBA degree has had on his career and self-confidence.

"My life has seen a complete change because of my MBA. I am proud to be the first member of my family to earn a college degree and a world of possibilities has opened up. The route I chose was not the traditional one, but it's worked out well for me. To fellow military personnel who are

"MY LIFE HAS SEEN A COMPLETE CHANGE BECAUSE OF MY MBA. I AM PROUD TO BE THE FIRST MEMBER OF MY FAMILY TO EARN A COLLEGE DEGREE AND A WORLD OF POSSIBILITIES HAS OPENED UP. THE ROUTE I CHOSE WAS NOT THE TRADITIONAL ONE, BUT IT'S WORKED OUT WELL FOR ME."

Tyshawn Jenkins

on the fence or who may have never considered going back to school to finish their degree, I would say, 'just do it.' Continuing your education will be hugely beneficial to your future and I tell fellow service members that the most valuable investment they can possibly make is in themselves. As a military member, I urge them to take full advantage of the tuition assistance benefits to which they're entitled."



Dave Saffran/MSG Photos

Tyshawn Jenkins, MBA '15, was recognized during the Knicks vs. Celtics game in April 2017 by Knicks legend, Larry Johnson, at Madison Square Garden for service to his country and community.



Jenkins spends time reading to school-aged children as part of his efforts to continually give back to the community.



class notes

❖ **Bernard Amponsah** AAS '04, MSHM '17

Bernard Amponsah was honored by his employer, Cornell University, for being an employee who has completed his education and lifelong dream. He hopes to eventually start his own tourism development and finance company to help develop infrastructure in Africa.

❖ **Ray Bowman** BSBA '09, MSM '10

ALUMNI AMBASSADOR

Ray Bowman has received the Association of Small Business Development Center's (SBDC) 'State Star' award for his organization's contribution to California's Small Business Development Center. The districtwide award honors one of the 12 local SBDCs for implementing innovative programs and actively developing counseling staff to advance opportunities for area businesses interested in international trade development. Bowman, SBDC director of Ventura and Santa Barbara counties, accepted the award in May.

❖ **Patrina Clark** BA '04

Patrina Clark, president and founder of Pivotal Practices Consulting LLC, in Greenbelt, Md., attended a special reception in the Oval Office of the White House for her firm's selection as a 2017 Professional Services Firm of the Year by the U.S. Department of Commerce's Minority Business Development Association (MBDA). Clark was one of 15 minority business enterprises (MBEs), businesses leaders and advocates recognized for their leadership, commitment and excellence in advancing the interests and the economic achievements of the minority business community. Clark was also honored in November for being selected as a Top 100 MBE (Minority Business Enterprise) by the Capital Region Minority Supplier Diversity Council. This award recognizes owners of minority business enterprises in Maryland, Virginia and the District of Columbia who have demonstrated exceptional entrepreneurial accomplishments, a high level of professionalism and have made substantial contributions to their communities.



❖ **Mark DiCarlo** BSHS '05

Mark DiCarlo was named chief of the Morris Township Police Department in New Jersey. DiCarlo served a decade as a patrolman with the department, which included some time with the special enforcement unit of the Morris County Prosecutor's Office. Later, DiCarlo was assigned to the detective bureau in 2006.



He made captain in 2016, serving along the way as the department's field training and communications officer, and firearms instructor before being named chief.

❖ **Joel P. Faircloth** BA '99

Joel P. Faircloth was named chief investment officer of Aspen Wealth Strategies in Arvada, Colo. After graduating from the University in 1999, Faircloth earned his Master of Business Administration degree from Villanova University in Villanova, Pa., and moved from New Jersey to the Pacific Northwest in 2011. Faircloth is responsible for the investments of hundreds of clients across most of the United States.



❖ **Glenn George** BSAST '09, MSM '13

Glenn George has earned a Master of Science in Electrical Engineering (MSEE) degree from Michigan Technological University in Houghton, Mich., and passed the Professional Engineer (PE) Electrical Power Engineering exam administered by the National Council of Examiners for Engineering and Surveying. George works for Exelon as a senior substation engineer and teaches electrical power engineering and industrial engineering engineer-in-training courses.

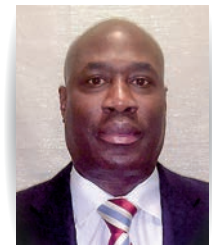

❖ **Terri-Lynn Hamby** BA '05

Terri-Lynn Hamby earned her doctorate in educational leadership on May 20, 2017, from the University of New England in Biddeford, Maine. She is currently the assistant director of Science Labs at Atlantic Cape Community College in Mays Landing, N.J.



❖ **Nicole Henderson** BSBA '11

Nicole Henderson has released a new book, *Storm Clouds Are Passing: Hold On Until Change Comes*. The book can be found on authorhouse.com.

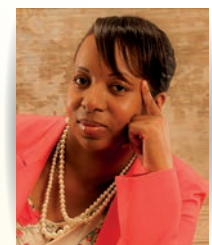

❖ Mabel Huynh MAEdL '09

Mabel Huynh was named assistant principal of Westfield High School in Westfield, N.J.

❖ Seth Kurs BA '00

ALUMNI AMBASSADOR

Seth Kurs was sworn in as the Municipal Court Judge of Hightstown, N.J., in October. Kurs was a council member in Hightstown from 2014 to 2017 prior to his appointment.

❖ Jennifer Johnson

AA '12, BSBA '16

Jennifer Johnson is currently working toward her Master of Science in Accountancy (MSA) degree at the University of Illinois in Champaign, Ill. She expects to graduate in December.



❖ Eric Petrevich

BSHS '05, MSM '09,
BSBA '12

ALUMNI AMBASSADOR

Eric Petrevich was promoted to major in the United States Army in October. The ceremony took place in the Office of the Chief of Engineers at the Pentagon in Washington, D.C. Petrevich serves with the G2 staff for the Army Corps of Engineers in Washington, D.C. He has been activated for hurricane support for Hurricanes Harvey, Irma and Maria since September.



❖ Stephen Rally BA '10

ALUMNI AMBASSADOR

Stephen Rally has earned a master's degree in Secondary Education and became a certified teacher. He is currently a social studies teacher and department coordinator at a high school in Pennsylvania.

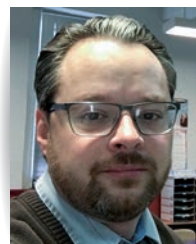

❖ Jeff Steward

BSAST '97

Jeff Steward was named by the U.S. Nuclear Regulatory Commission (NRC) as resident inspector of Brunswick Nuclear Power Plant near Southport, N.C. Steward, who joined the NRC in March 2016, served as a reactor engineer in the NRC's Region III office in Lisle, Ill., before being named to his new position.



❖ Dr. J. A. Stephen Viggiano BA '82

Dr. J. A. Stephen Viggiano presented a paper entitled, "Calculation of Scalars in Neugebauer-Type Models. I: Refactoring the Calculations" at the 25th Color and Imaging Conference held in Lillehammer, Norway. Viggiano teaches photographic science at Rochester Institute of Technology in Rochester, N.Y.

ALUMNI AMBASSADOR

To learn more about the Alumni Ambassador program at Thomas Edison State University, please visit www.tesu.edu/ambassador

To connect with the Office of Alumni Affairs and fellow TESU alumni, join the conversation on social media:

Alumni Facebook Group: www.tesu.edu/FacebookGroup

Student and Alumni LinkedIn Group: www.tesu.edu/LinkedInGroup

Keep us posted!

Submit your news online at:
www.tesu.edu/classnotes

Updates can also be sent to:

THOMAS EDISON STATE UNIVERSITY
INVENTION EDITOR
111 W. STATE ST.
TRENTON, NJ 08608

or Invention@tesu.edu



Thomas Edison State



@tesu_edu



@tesu_edu



Thomas Edison
State University



blog.tesu.edu



Thomas Edison State

